

HA36汽油机分解图
The Parts List of Model
HA36 Engine

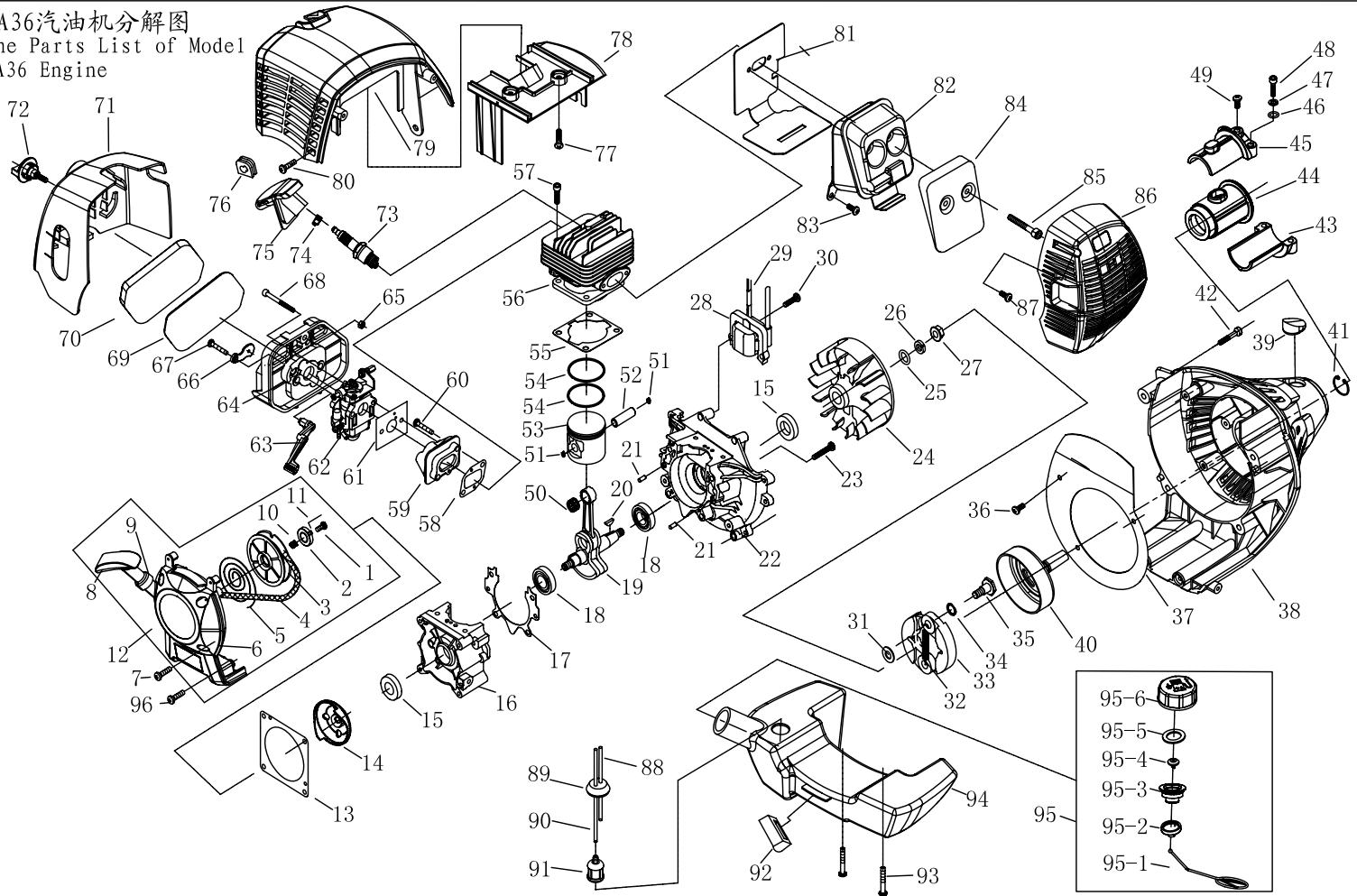

序号 NO.	代号 Part No.	名称 Part Name	数量 Qty.	序号 NO.	代号 Part No.	名称 Part Name	数量 Qty.	序号 NO.	代号 Part No.	名称 Part Name	数量 Qty.	序号 NO.	代号 Part No.	名称 Part Name	数量 Qty.
1	1E36FE. 9-3	螺钉 Screw	1	30	GB9074. 13	螺栓组合件 M5 × 20 Bolt M5 × 20	2	59	HA36-3	进气管 Admitting Pipe	1	88	EB-415. 4. 2-4	透明塑料管 Fuel Pipe	0. 06
2	1E36FE. 9-4	起动机 Ratchet	1	31	1E36F-3	垫圈B Washer B	2	60	GB9074. 4	螺钉组合件 M5 × 20 Screw M5 × 20	2	89	EB-415. 4. 2-2	油管塞 Plug	1
3	1E36FE. 9-1	绳轮 Start Rope Reel	1	32	1E36F-E. 6B-1	拉簧 Spring	1	61	1E36F-E-11	化油器垫 Gasket	1	90	CG420. 1. 3. 2-2	透明塑料管 Fuel Pipe	0. 125
4	1E36FE. 9-5	起动机拉绳 Rope	1	33	1E36F-2C. 4. 1	涨紧块 Expander	2	62	1E36F-E. 1B	化油器 Carburetor	1	91	P40. 12. 2-3A	燃油过滤器 Cleaner Cover	1
5	1E36FE. 9-7	起动机平簧 Recoil Spring	1	34	1E40F-5-11	波形垫圈 Washer	2	63	HA36. 4. 1-3	阻风门手柄 Choker Handle	1	92	1E40F-5A-2	橡胶套 Rubber Cover	1
6	HA36. 6-1	起动机壳体 Start Cover Ass'y	1	35	P40-18	螺钉轴 Screw Pin	2	64	HA36. 4. 1-1	空滤器内罩 Cleaner inside cover	1	93	GB9074. 4	螺钉组合件 M5 × 16 Screw M5 × 16	2
7	GB9074. 4	螺钉组合件 M5 × 14 Screw M5 × 14	4	36	GB845	螺钉 ST4. 2X9. 5 Screw ST4. 2X9. 5	3	65	GB/T6170	螺母 M4 Nut M4	1	94	1E36FE. 10-1	油箱 Fuel Tank	1
8	CG520-HL. 5-1	起动手柄 Start Handle	1	37	HA36. 3-1	引风板 Shutterer	1	66	HA36. 4. 1-2	阻风门 CHOKER	1	95	1E32FL. 6. 2	油箱盖组合 Lid Ass'y	1
9	HA36. 6-2	导向套 Ring	1	38	HA36. 3. 1	连接盘 Clutch Case	1	67	GB/T846	自攻螺钉 ST4. 2 × 13 Screw ST4. 2 × 13	1	95-1	1E32FL. 6. 2-4	防脱链 Chain	1
10	1E36FE. 9-6	压簧 Spring	1	39	HA36. 3-2	堵头 Stoppie	1	68	GB/T9074. 4	螺钉组合件 M5 × 55 Screw M5 × 55	2	95-2	1E32FL. 6. 2-3	端盖 End Cover	1
11	1E36FE. 9-2	起动机扳杆 Start pole	2	40	HA36. 3. 2	被动盘离合 Clutch Drum Comp.	1	69	HA36. 4-3	滤芯挡板 Filter Net Shutterer	1	95-3	1E32FL. 6. 2-2	油箱内盖 Inside Cover	1
12	HA36. 6	起动机 Starter	1	41	GB/T894. 1	挡圈15 Stop Ring 15	1	70	HA36. 4-2	滤芯 Filter Net	1	95-4	EB-415. 4. 1. 1-1	进气嘴 Inlet	1
13	1E40F-3D-3	防尘垫 Gasket	1	42	GB70. 1+GB93+GB97	螺钉组合 M5 × 16 Screw M5 × 16	4	71	HA36. 4-1	空滤器外罩 Cleaner Outside Cover	1	95-5	CG420. 1. 3. 1-2	密封垫 Gasket	1
14	1E36FE. 7	起动机扳盘离合 Start Reel	1	43	CG305F-HS. 1-2	半圆夹板B Clamp B	1	72	HA28L. 1. 1	大头螺钉 Screw	1	95-6	1E32FL. 6. 2-1	油箱盖 Fuel Tank Lid	1
15	1E36F. 2	小油封 Oil-seal	2	44	CG305F-HS. 1-3	减振套 Rubber Cover	1	73	L8RTC	火花塞 Spark Plug	1	96	GB/T845	Screw ST4. 2 × 16	2
16	1E36F-E. 8-2	后半曲轴箱 Crank Case	1	45	CG305F-HS. 1-1	半圆夹板A Clamp A	1	74	1E40F-3A. 8-2	火花塞卡簧 Spring	1				
17	1E36F-2. 6-3	曲轴箱密封垫 Gasket	1	46	GB97. 1	垫圈5 Washer5	2	75	HA36. 2. 1-1	高压帽 Cap	1				
18	GB/T276	轴承 6201/P6 Bearing 6201/P6	2	47	GB93	垫圈5 Washer5	2	76	1E40F-5. 3-1	胶塞 Plug	1				
19	1E36F-E. 4. 1	曲轴连杆组 Crank Shaft	1	48	GB70. 1	螺钉 M5 × 16 Screw M5 × 16	2	77	GB845	螺钉 ST4. 2X9. 5 Screw ST4. 2X9. 5	2				
20	GB1099	半圆键 3 × 5 × 13 Key 3x5x13	1	49	GB9074. 4	螺钉组合件M5 × 16 Screw M5 × 16	1	78	HA36-2. 5-1	缸体隔板 Guide Clapboard	1				
21	GB119	销 B4 × 10 Pin B4 × 10	4	50	1E36F-2. 4. 1	小头滚针轴承 Bearing	1	79	HA36. 8-2	缸体护罩 Guide Cover	1				
22	HA36. 5-1	前半曲轴箱 Crank Case	1	51	1E36F. 10-2	活塞销挡圈 Ring	2	80	GB846	螺钉 ST2. 9X9. 5 Screw ST2. 9X9. 5	2				
23	GB70. 1	螺钉 M5 × 30 Screw M5 × 30	4	52	1E36F. 10-1	活塞销 Piston Pin	1	81	HA36-1	消音器垫 Gasket	1				
24	1E36F-2E. 2. 1. 1	磁电机转子 MAGNETO ROTOR COMP.	1	53	1E36F-E. 4-1	活塞 Piston	1	82	HA36. 1	消音器 Muffler	1				
25	GB/T859	垫圈8 Washer8	1	54	1E36F. 10-3	活塞环 Piston Ring	2	83	GB9074. 4	螺钉组合件M5 × 12 Screw M5 × 12	1				
26	GB/T97. 1	垫圈8 Washer8	1	55	1E36F-E-3	缸垫 Gasket	1	84	1E36F-2E-3	隔热罩 Cover	1				
27	GB6170	螺母 M8 Nut M8	1	56	1E36F-2E-1	缸体 Cylinder	2	85	GB70. 1+GB93+GB97	螺钉组合 M5 × 60-12. 9 Screw M5 × 60-12. 9	2				
28	HA36-2. 4. 1. 1	磁电机定子 IGNITION COIL COMP.	1	57	GB/T70. 1	螺钉 M5 × 18 Screw M5 × 18	4	86	HA36-2	消音器护罩 Muffler Cover	1				
29	1E36F-2. 3. 1	停车线组 Cord Comp.	1	58	1E36F-E-8	进气管垫 Gasket	1	87	GB/T845	自攻螺钉 ST4. 2 × 13 Screw ST4. 2 × 13	3				

BRUSHCUTTER MACHINE SPARE PARTS LIST BC36

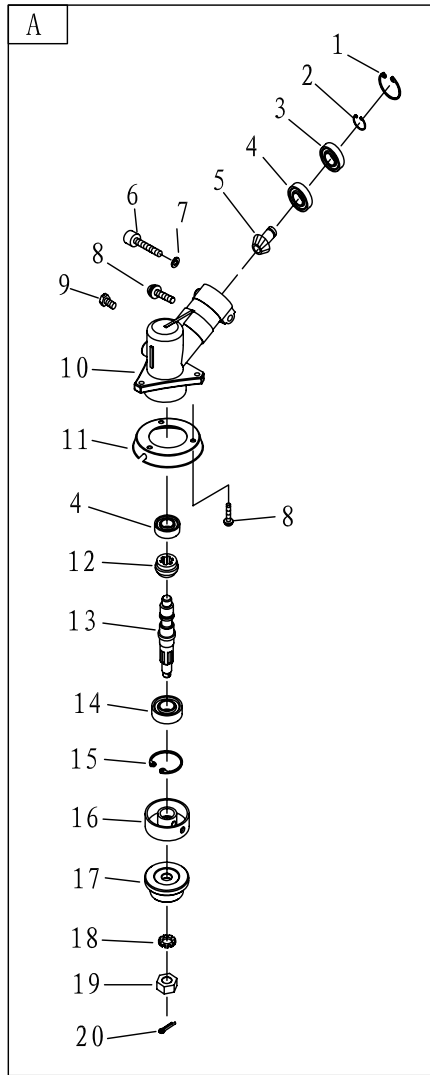

NO.	PART NO.	PART NAME	QTY.
A	CG415. 3	Gear Case Ass'y	
1	GB/T893. 2	Stop Ring 26	1
2	GB/T894. 1	Stop Ring 10	1
3	GB/T276	Bearing 6000-2RS/P6	1
4	GB/T276	Bearing 6000/P6	2
5	CG415D. 6-4	Pinion	1
6	GB/T70. 1	Screw M6×20	1
7	GB/T93	Washer 6	1
8	GB/T9074. 4	Screw M5×12	4
9	GB/T9074. 11	Bolt M6×12	1
10	BG305. 12. 4-4	Gear Case	1
11	BG330H. 7. 3-1	Safety Guard	1
12	BG-328. 9. 5-2	Gear	1
13	CG305F. 1-1	Gear Shaft	1
14	GB/T276	Bearing 6002-2RS/P6	1
15	GB/T893. 2	Stop Ring 32	1
16	BC34. 3-1	Holder A	1
17	CG305F. 1-3	Holder B	1
18	GB/T862. 1	Washer 10	1
19	CG305F. 1-4	Left Nut	1
20	GB/T91	Pin 2×16	1

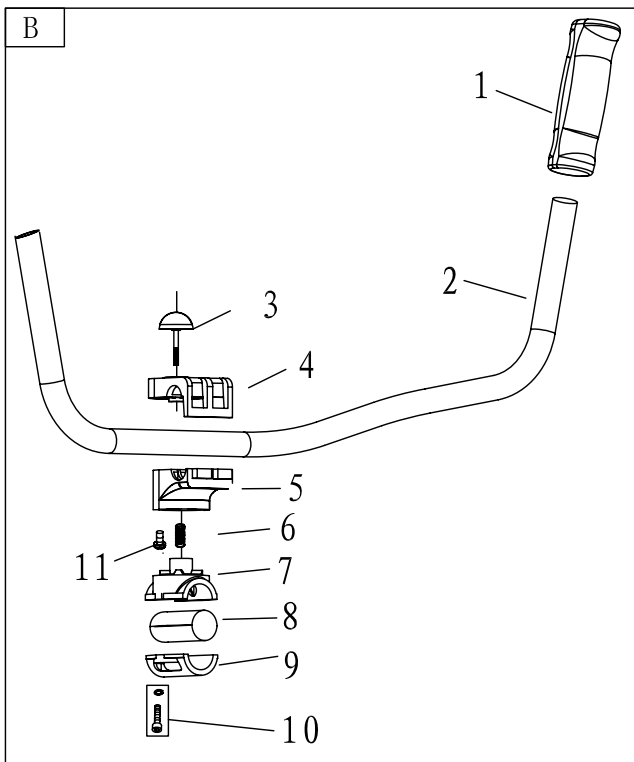

NO.	PART NO.	PART NAME	QTY.
B			
1	BC36-8	Rubber Ringer	1
2	BC36-6	HANDGRIP	1
3	BC36. 2A	Lock Bolt	1
4	BC36-5A	CAP, UPPER	1
5	BC36-3A	BRACKET	1
6	BC36-4	Spring	1
7	BC36-2A	Eddy Seat	1
8	BC36-10	Damping Cushion	1
9	BC36-1	CAP, Lower	1
10	BC36. 4-2+GB93	Screw M5*20	2
11	BC36-SB-1	Screw M5*10	1

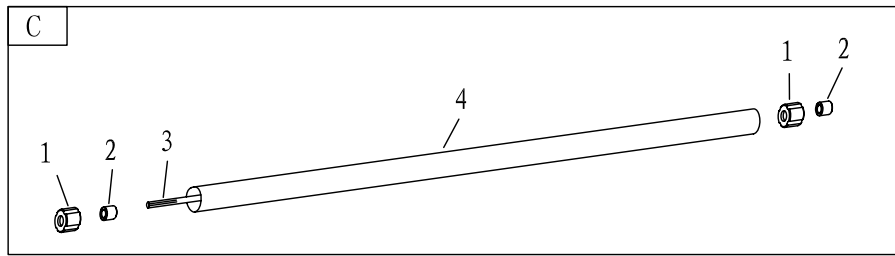

NO.	PART NO.	PART NAME	QTY.
C	BC36. 1	Pipe Comp.	1
1	BG-328. 9. 4-5	Rubber Cover	6
2	BG-328. 9. 4-4	Oil-bearing	6
3	CG40. 3-2	Drive Shaft	1
4	BC36. 1-1	Pipe	1

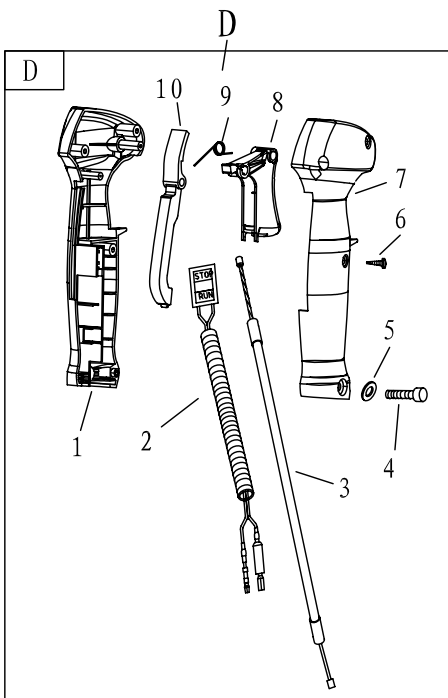

NO.	PART NO.	PART NAME	QTY.
D	BC36. 3	Lever Ass'y	
1	BC36. 3. 3	Box, Left	1
2	BC36. 3. 1	Stop Button Comp.	1
3	BC36. 3. 2	Cable Comp.	1
4	GB/T818	BOLT M5*30	1
5	GB/T848	WASHER 5	1
6	GB/T845	BOLT ST3. 5*13	4
7	BC36. 3-1	Box, Right	1
8	BC36. 3-6	Handgrip	1
9	BC36. 3-5	Spring	1
10	BC36. 3-3	HANDGRIP	1

BRUSHCUTTER MACHINE SPARE PARTS LIST BC36

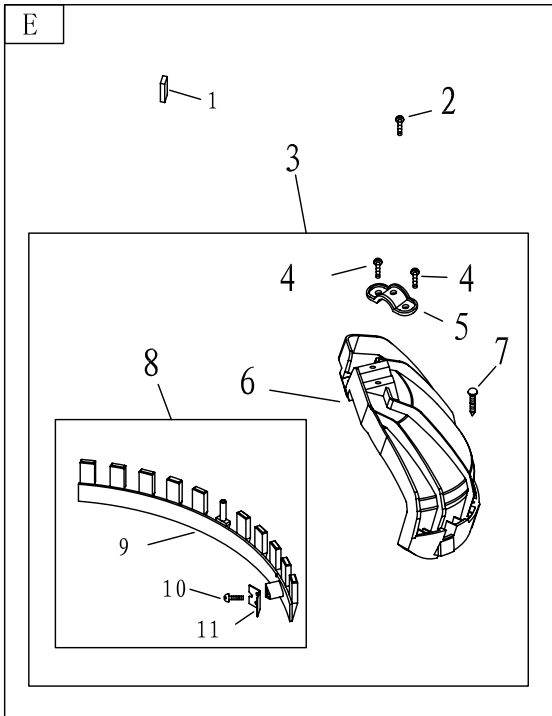

NO.	PART NO.	PART NAME	QTY.
E			
1	BC46-5	Blade Cover	1
2	GB/T70.1	BOLT M5*10	2
3	BC36.4	Guard Ass'y	1
4	BC36.4-2	Screw M5*12	2
5	BC36.4-1	SAFETY GUARD BRACKET	1
6	BC36.4.1	Safety Guard	1
7	GB/T845	Screw ST4.2×16	1
8	BC46.2.2	Guard Ass'y	1
9	CG420.7.1.1-1	Guard	1
10	GB/T845	Screw ST4.2×16	2
11	BC46.2.2-1	Blade	1

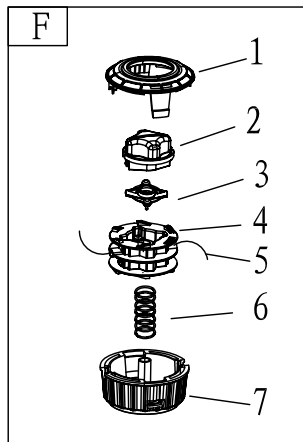

NO.	PART NO.	PART NAME	QTY.
F	BC36.5	Nylon Cutter Head	
1	BC36.5-2	CAP Rope Room	1
2	BC36.5-1	Bounce Object	1
3	BC36.5-3	Rope Cap	1
4	BC36.5-4	Rope Seat	1
5		Cord ϕ 2.0×3100	1
6	BC36.5-6	Spring	1
7	BC36.5.1	Rope Room	1

BRUSHCUTTER MACHINE SPARE PARTS LIST BC36

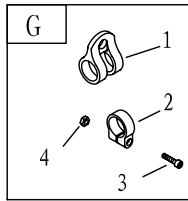

NO.	PART NO.	PART NAME	QTY.
G	CG260. 3	Holder Ass'y	
1	CG260. 3. 1	Harness Clamp	1
2	CG260. 3-1	Clamp	1
3	GB/T70. 1	Screw M5×20	1
4	GB/T889. 1	Nut M5	1

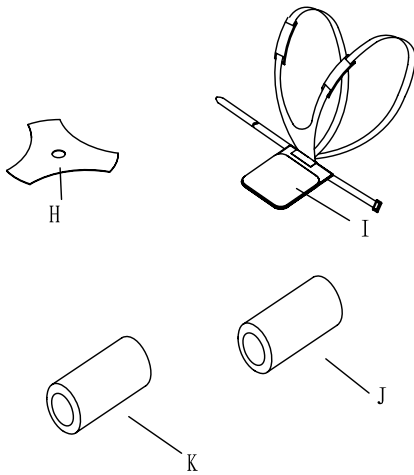

NO.	PART NO.	PART NAME	QTY.
H	CG420-2	Blade	1
I	CG260A-CE. 1	Harness Ass'y	1
J	BC46-7	Bubble Jacket A	1
K	BC46-6	Bubble Jacket	1